

The reproduction, distribution and disclosure of this document as well as the communication of its contents to other without express authorization is prohibited. Offenders will be held liable for payment of damages. All rights reserved in the event of the grant of a patent, utility model or design.

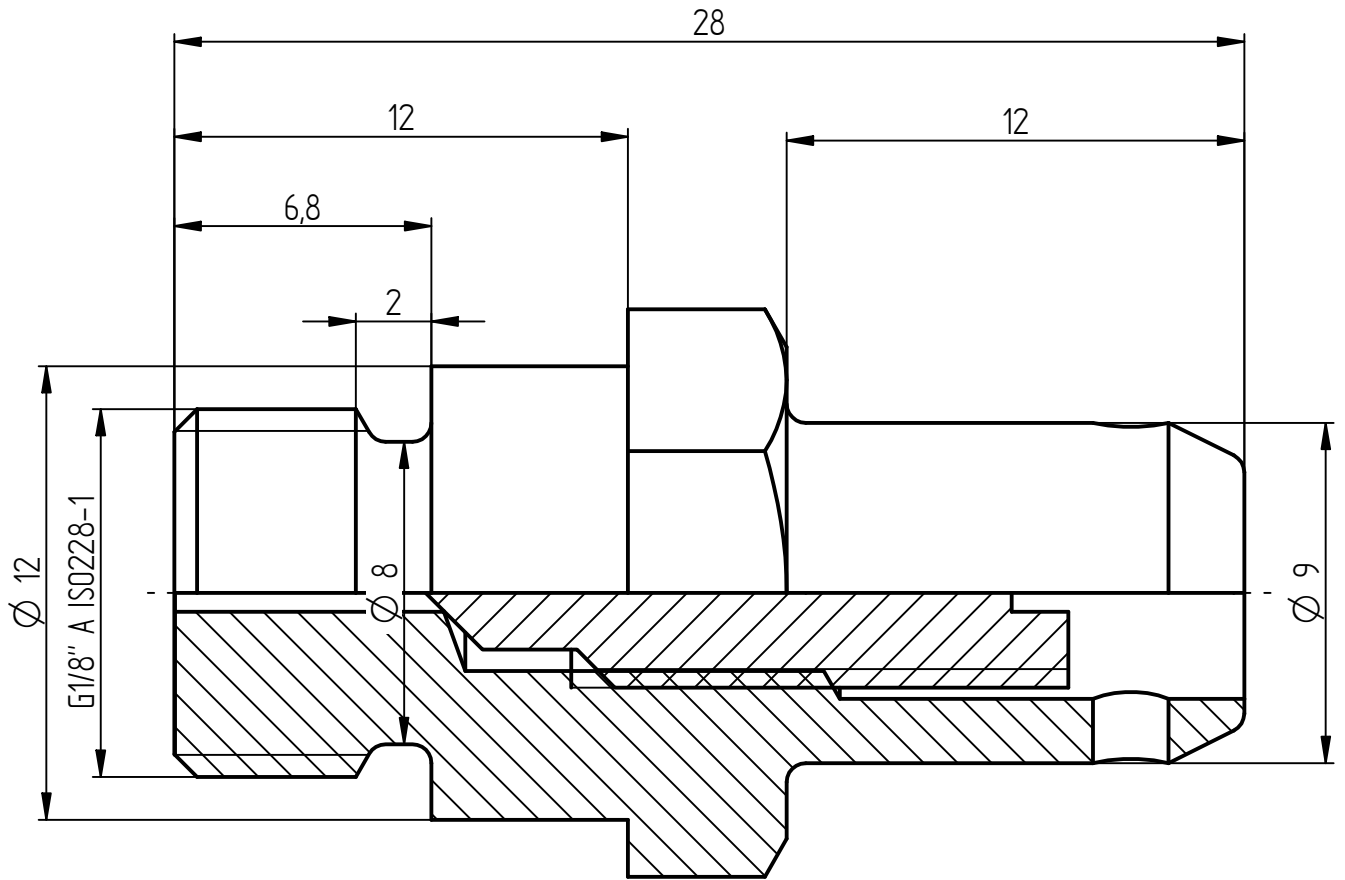

				Halbzeug/Werkstoff (semifinished product/material)		Allgemeintoleranz (General tolerances)		Blatt	
				Messing		ISO 2768-m-K		1	
						Benennung (name)		Blattanzahl	
				Prüfstopfen 1/8" (Messing)		Maßstab (scale)		1	
						A4 5:1		Freigegeben	
A	11/2016	15.04.2016	R.Golla			Masse		0,020 kg	
AZ	Mitteilung	Datum	Name						
Gezeichnet		Datum	Name	Dokumenten-Nr. (document-No.)	Revision	Modelldatei		700047-A.asm	
Konstr.		22.06.2006		700047_KAT		System:		Solid Edge	
Geprüft				Art.-Nr. (item-No.)		Änderungen nur im 3D-Modell gültig!		Zeichnung unterliegt nicht dem Änderungsdienst!	
Norm.				70-001-018		Ers. fuer		Ers. durch	